

(No Model.)

Z. B. COES.
FEED MECHANISM FOR LATHES.

No. 462,792.

Patented Nov. 10, 1891.

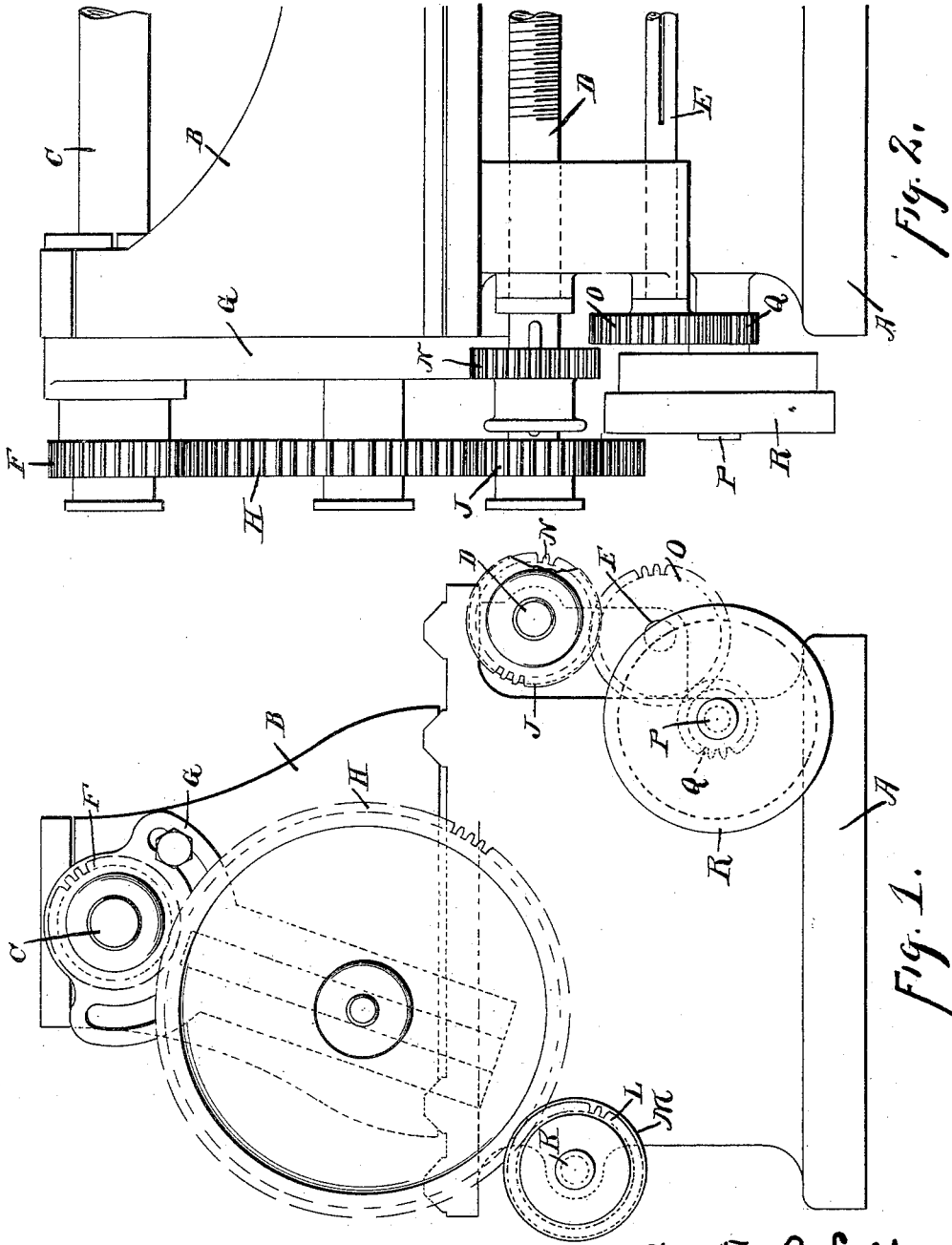

Fig. 2.

Fig. 1.

Zorster B. Coes

Inventor
by James W. See
Attorney

Witnesses:
P. P. Sheehan
Jessie Banck

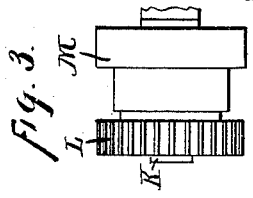

UNITED STATES PATENT OFFICE.

ZORESTER B. COES, OF HAMILTON, OHIO, ASSIGNOR TO THE NILES TOOL WORKS, OF SAME PLACE.

FEED MECHANISM FOR LATHES.

SPECIFICATION forming part of Letters Patent No. 462,792, dated November 10, 1891.

Application filed July 6, 1891. Serial No. 398,490. (No model.)

To all whom it may concern:

Be it known that I, ZORESTER B. COES, of Hamilton, Butler county, Ohio, have invented certain new and useful Improvements in Feed Mechanism for Lathes, of which the following is a specification.

This invention pertains to improvements in the feed mechanism of engine-lathes, and the improvements will be readily understood from the following description, taken in connection with the accompanying drawings, in which—

Figure 1 is an end elevation of a lathe provided with feed mechanism exemplifying my improvements; Fig. 2, a front elevation of this mechanism, and Fig. 3 a front elevation of the rear pulley M.

In the drawings, A indicates the lathe-bed; B, the head-stock; C, the lathe-arbor; D, the lead-screw; E, the feed-rod; F, a pinion to be driven positively by the lathe-arbor, the exemplifying drawing showing this pinion as secured directly to the arbor; G, a tumbler fitted for angular adjustment with reference to the axis of the pinion F; H, a swinging change-gear mounted upon a stud carried by the tumbler, this change-gear gearing with the pinion F; J, a change-gear on the lead-screw in position to be engaged by the swinging gear when that gear is swung forward; K, a stud supported by the lathe-bed to the rear of the vertical plane of the pinion F; L, a pinion mounted on this stud and adapted to be engaged by the swinging gear H when that gear is swung rearwardly, as indicated in Fig. 1; M, a belt-pulley, shown as having two steps, fast with the pinion L; N, a slip-gear splined to the lead-screw and adapted to slide thereon a distance equal at least to the length of the gear-teeth; O, a gear fast on the feed-rod and engaged by the slip-gear N when the slip-gear is moved into active position; P, a stud supported by the lathe-bed near the feed-rod; Q, a pinion mounted thereon and engaging the gear O; R, a pulley fast with pinion Q and shown as having two steps to match the pulley M, pulleys M and R being in the same plane, so that a belt may engage them both.

When the lead-screw is to be employed in screw-cutting, then the change-gears F, H, and J are to be selected and adjusted in an ob-

vious manner. The slip-gear N being pulled to the left, as shown in Fig. 2, the motions are transmitted no farther than to the lead-screw, so far as the present mechanism is concerned. If it be desired to employ the feed-rod for feeding purposes, then the slip-gear is pushed to the right, whereupon the feed-rod revolves at a relative velocity determined by the proportion of gearing at O and N and under control by selection of change-gears. As the feed-rod rotates the pulley R also rotates and drives the pulley M idly. Having under the above-mentioned conditions a certain speed of rotation for the feed-rod adapted to certain classes of work and desiring a slower speed without the necessity for changing gearing, we have only to push the swinging gear H to the rear, thereby disconnecting it from the lead-screw and engaging it with the pinion L, whereupon the motion becomes transmitted from the swinging gear to gear L, causing pulley M to turn the belt, which will be upon pulleys M and R, thereby transmitting rotary motion to the feed-rod at a rate of speed due to the proportion of parts, and while the feed-rod is thus being driven through the belt the slip-gear N may, if desired, be moved to idle position, so that the lead-screw need not rotate. By this system it becomes possible to change from one speed of feed to another speed of feed by a simple swinging motion of a gear, and to have the heaviest feeding motion transmitted positively through gearing while the lighter feeding motion is through a belt. The transition from lead-screw work to belt-feed is made by a simple motion of the swinging gear, and the lead-screw may, if desired for feeding purpose, be driven through the medium of the belt. In the construction shown in the drawings the belt may be shifted on the steps of the pulleys, thus giving two changes of feeding by this means. Disregarding this last manner of change, the system gives four feeding speeds without changing gears—namely, one by means of the lead-screw when driven direct from the swinging gear, one by means of the lead-screw when driven through the belt and the gearing O and N, one by means of the feed-rod when driven by means of the gears J and N, and

one by means of the feed-rod when driven through gear L and the belt.

It will be understood by those skilled in the art that the mounting of the pulley R on a stud and gearing it to the feed-rod is a mere expedient for getting the pulley farther removed from the lead-screw, so as to give more room for the parts.

I claim as my invention—

1. In feed mechanism for lathes, the combination, substantially as set forth, of a lathe arbor, a gear driven thereby, a tumbler mounted to swing concentric to such gear, a lead-screw, a gear thereon, a gear and pulley mounted in fixed position, a swinging gear mounted on said tumbler and adapted to engage alternatively with said lead-screw gear and said pulley-gear, a feed-rod, and a pulley arranged to rotate the same and disposed in position to be driven by belt from the before-mentioned pulley.

2. In feed mechanism for lathes, the combination, substantially as set forth, of a lathe arbor, a gear driven thereby, a tumbler swinging concentric with such gear, a feed-rod, a pulley arranged to turn such feed-rod, a pulley supported in fixed position and arranged to be belted to the first-mentioned pulley and provided with a gear, a gear arranged to transmit rotary motion to the feed-rod, and a swinging gear mounted on said tumbler and adapted to swing into gear alternatively with said last mentioned gear and said pulley-gear.

3. In feed mechanism for lathes, the com-

35 bination, substantially as set forth, of a lathe arbor, a gear driven thereby, a tumbler arranged to swing concentric with such gear, a swinging gear carried by such tumbler, a pulley and gear mounted in fixed position and adapted to be driven by said swinging gear when swung to proper position, a lead-screw, a gear thereon adapted to be engaged by said swinging gear when swung into proper alternative position, a slip-gear on the lead-screw, a feed-rod, a gear thereon adapted to be engaged by said slip-gear, and a pulley arranged to turn the feed-rod and be belted from the first-mentioned pulley.

4. In feed mechanism for lathes, the combination, substantially as set forth, of a lathe arbor, a gear driven thereby, a tumbler arranged to swing concentric with such gear, a swinging gear carried by said tumbler, a pulley and gear adapted to be driven by said swinging gear when swung into proper alternative position, a lead-screw, a gear thereon adapted to be driven by said swinging gear when swung into proper position, a slip-gear on the lead-screw, a feed-rod, a gear thereon adapted to be engaged by said slip-gear, a pinion engaging the gear on the feed-rod, and a pulley fast with said pinion and adapted to be belted from the first-mentioned pulley.

ZORESTER B. COES.

Witnesses:

JAMES W. SEE,
J. N. SLAYBACK.